



(19) **United States**

(12) **Patent Application Publication**  
van Tooren et al.

(10) **Pub. No.: US 2018/0356118 A1**  
(43) **Pub. Date: Dec. 13, 2018**

(54) **3D PRINTED CONTINUOUS FIBER REINFORCED PART**

*B33Y 10/00* (2006.01)  
*B33Y 80/00* (2006.01)

(71) Applicants: **TIGHITCO, Inc.**, North Charleston, SC (US); **University of South Carolina**, Columbia, SC (US)

(52) **U.S. Cl.**  
CPC ..... *F24F 13/0281* (2013.01); *B29C 64/165* (2017.08); *B33Y 10/00* (2014.12); *B29L 2023/22* (2013.01); *F24F 13/0218* (2013.01); *F24F 13/0245* (2013.01); *B33Y 80/00* (2014.12)

(72) Inventors: **Michael Johannes Leonardus van Tooren**, Elgin, SC (US); **Ramy Harik**, Lexington, SC (US); **Wout De Backer**, Columbia, SC (US); **Arturs Peteris Bergs**, Cayce, SC (US); **Tawne Louis Castorina**, Coventry, CT (US)

(57) **ABSTRACT**

A part includes a continuous fiber substantially encased in a formation material. The fiber and formation material are arranged in a plurality of alternating layers such that the formation material of a first one of the alternating layers adheres to the formation material of a second one of the alternating layers over the length of the continuous fiber. The part may include a thin-walled hollow member such as a duct. In some embodiments a part comprises a continuous fiber prepared by an additive manufacturing process comprising the steps of: depositing a composite material on a print bed using a print head, the composite material comprising a continuous fiber and a formation material in intimate contact with the continuous fiber; moving the print head and/or the print bed during the depositing of the composite material; and consolidating the composite material.

(21) Appl. No.: **15/936,558**

(22) Filed: **Mar. 27, 2018**

**Related U.S. Application Data**

(60) Provisional application No. 62/478,132, filed on Mar. 29, 2017.

**Publication Classification**

(51) **Int. Cl.**  
*F24F 13/02* (2006.01)  
*B29C 64/165* (2006.01)

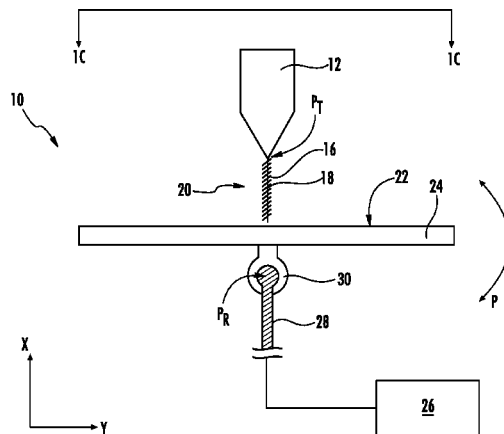
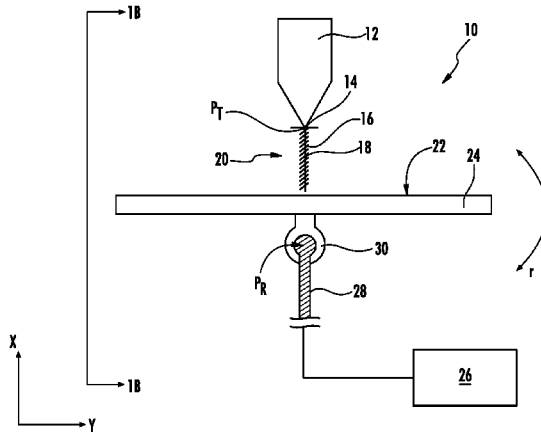

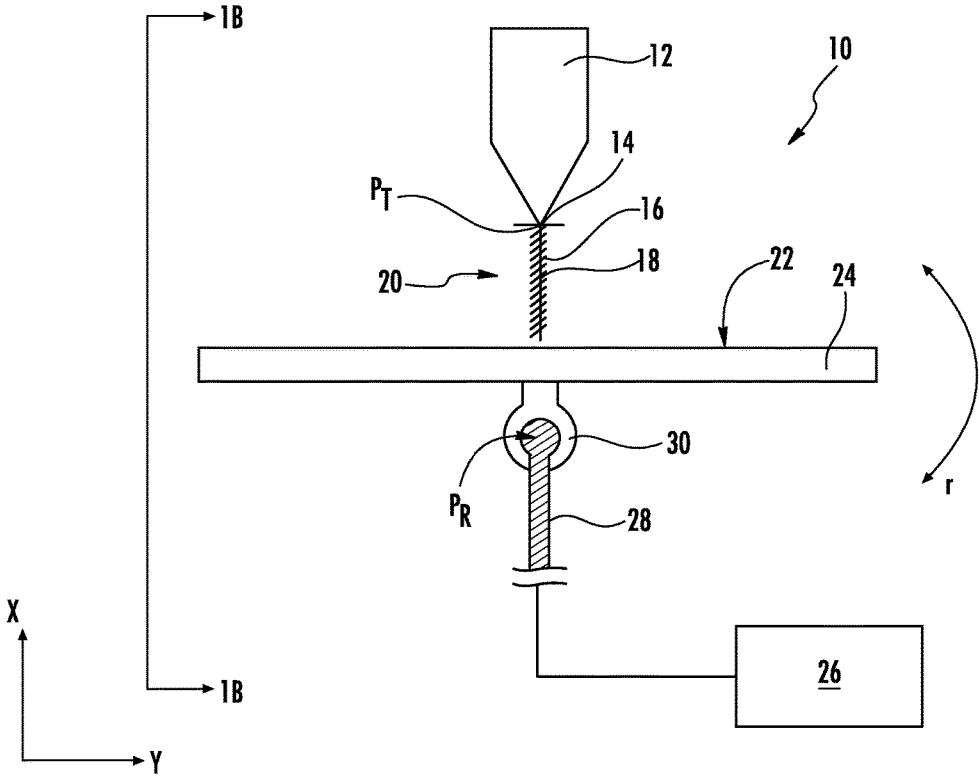

FIG. 1A

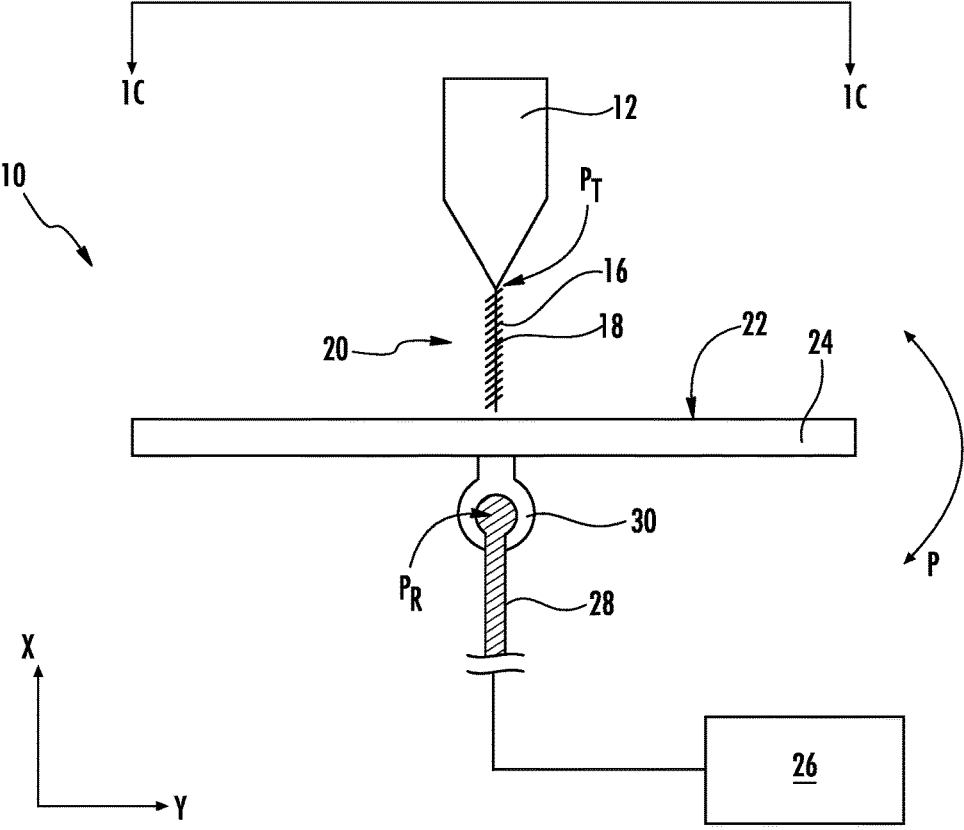

FIG. 1B

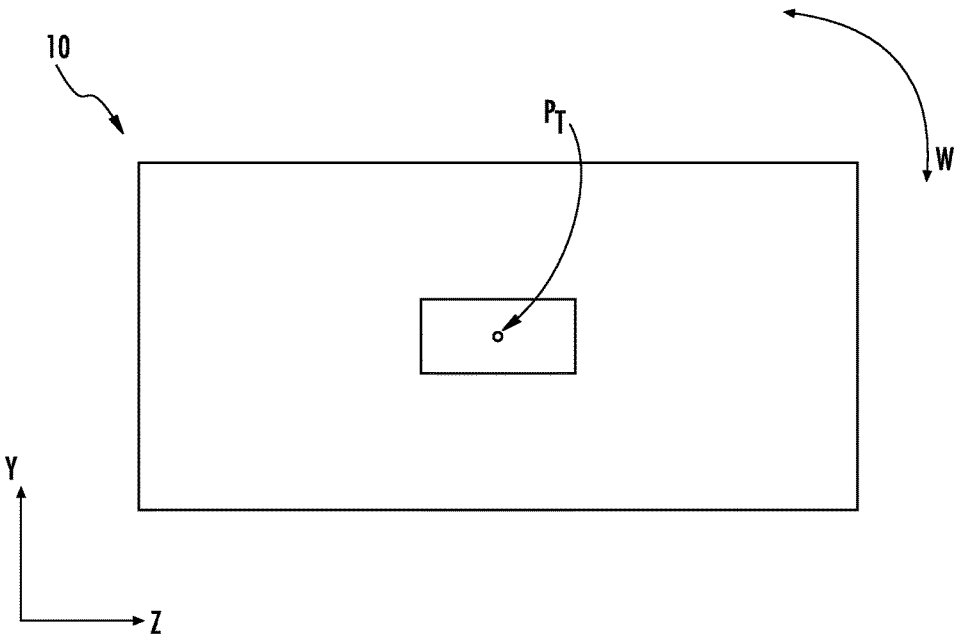

FIG. 1C

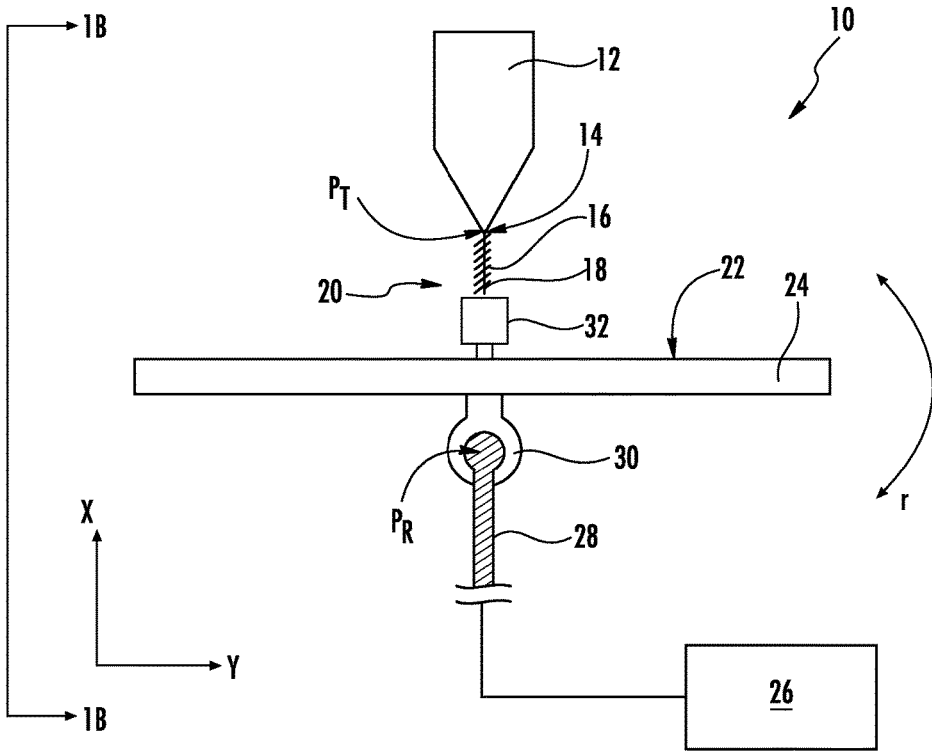
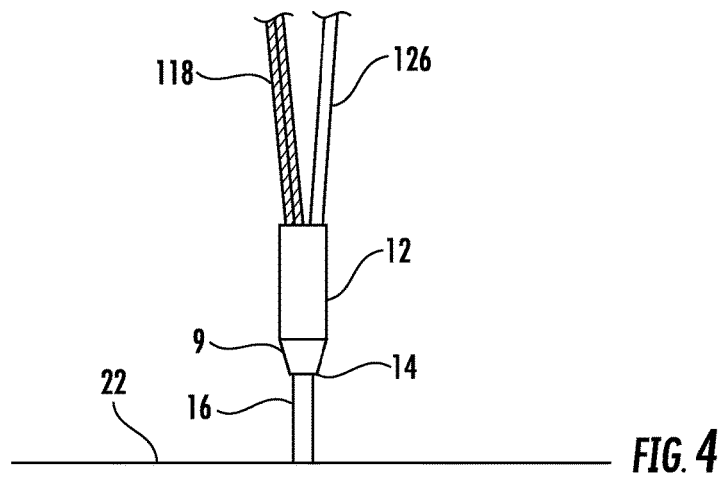
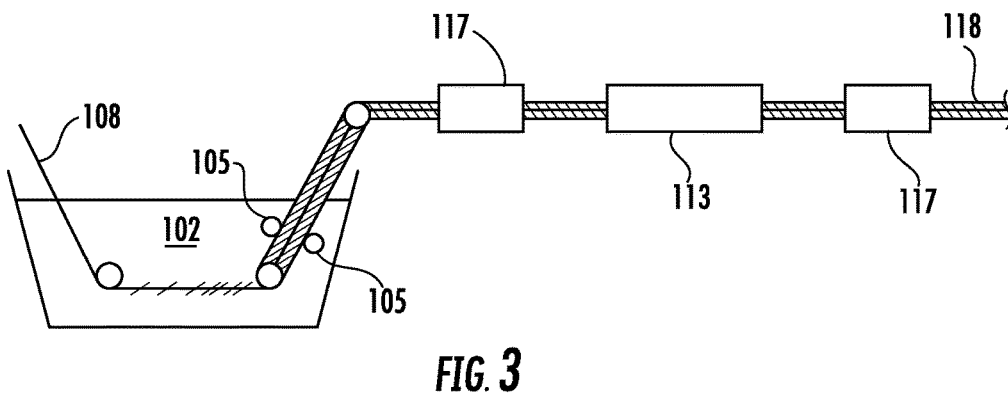
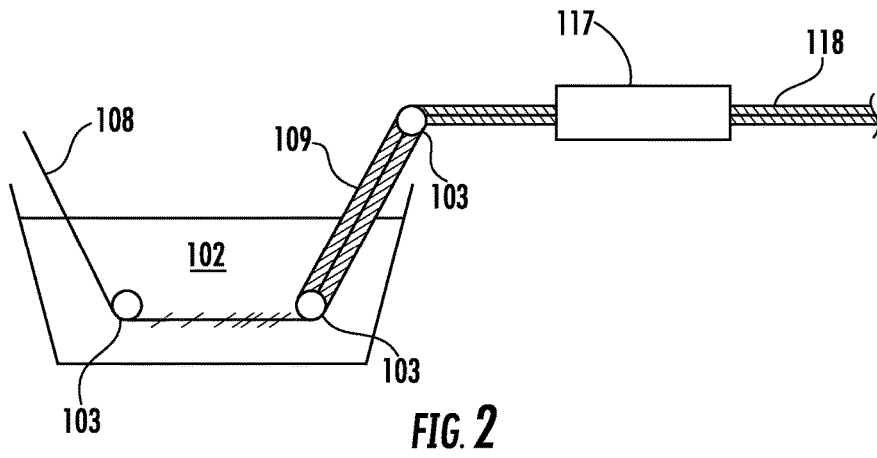

FIG. 1D



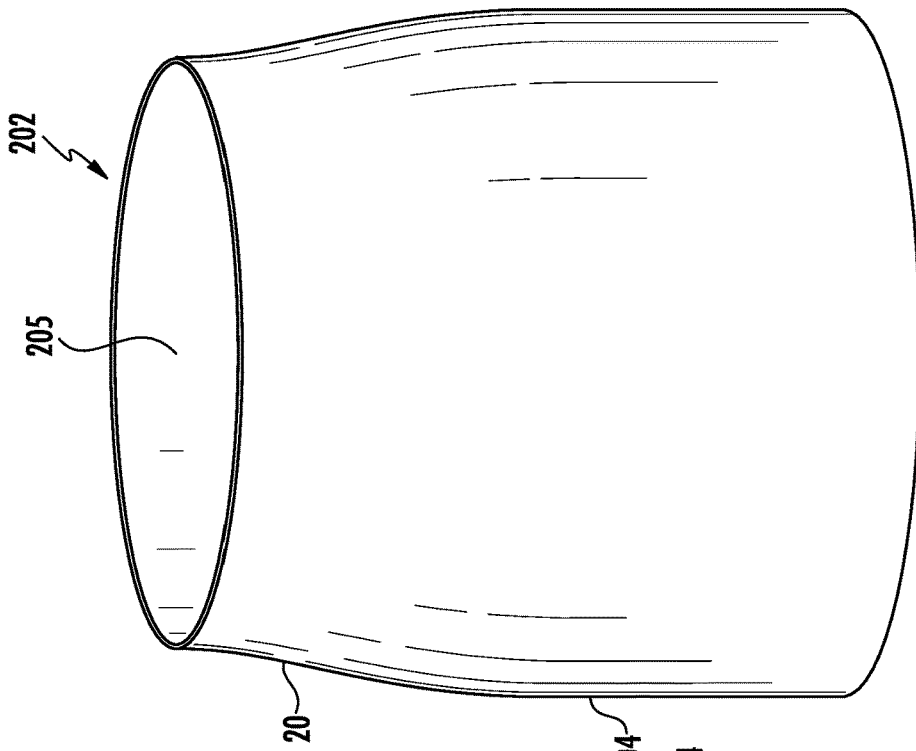

FIG. 7

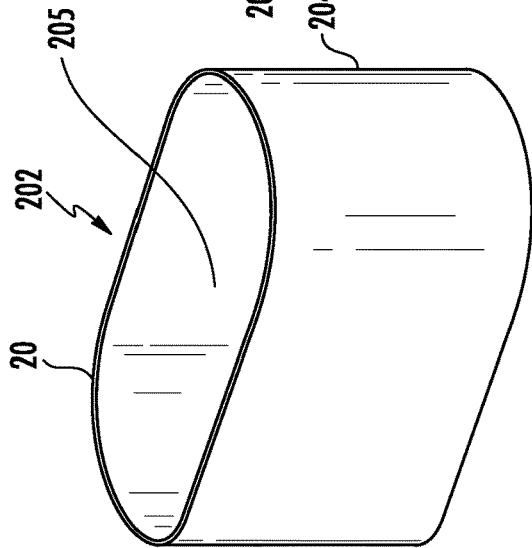

FIG. 6

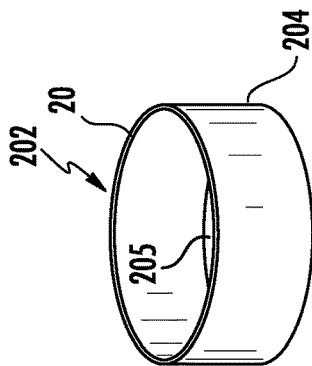
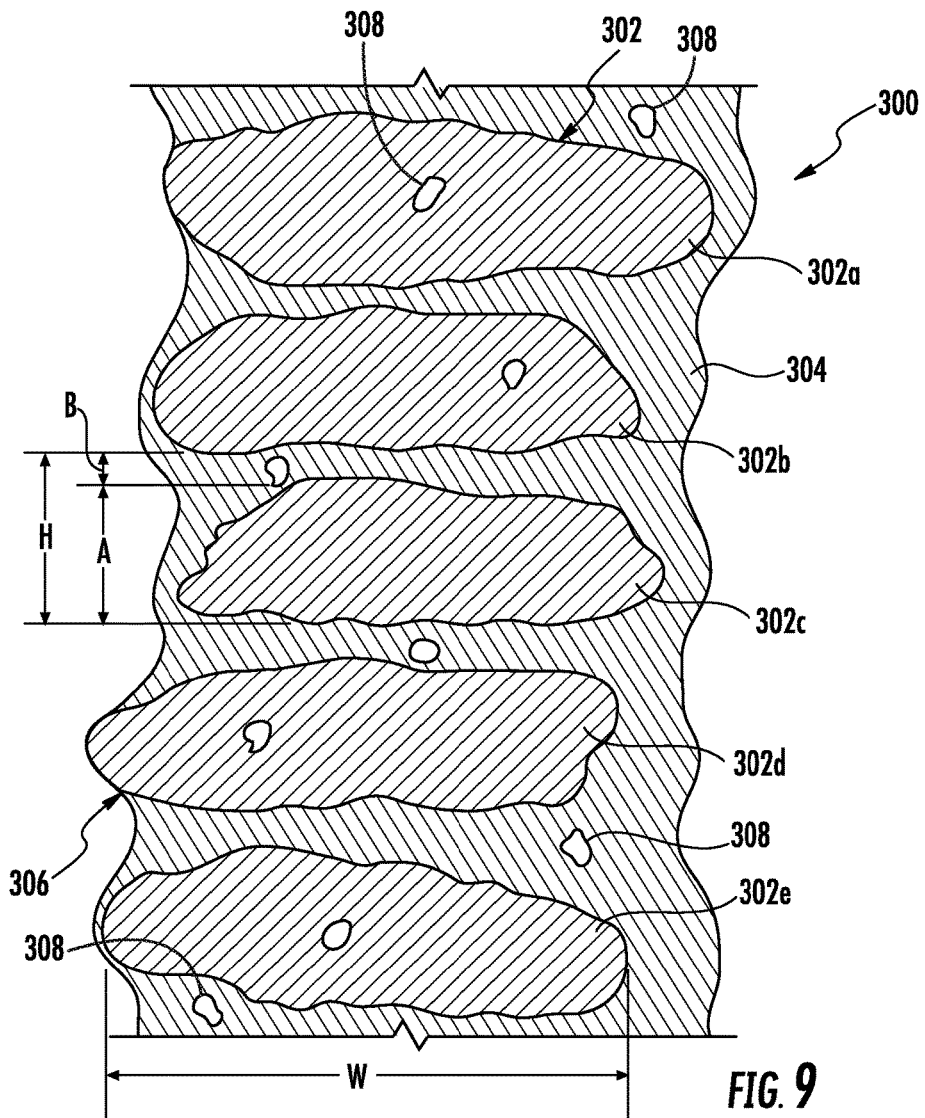
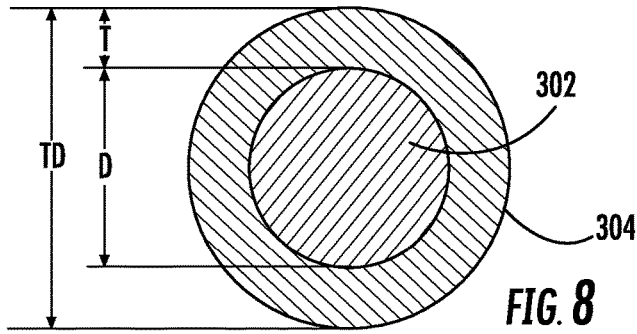

FIG. 5





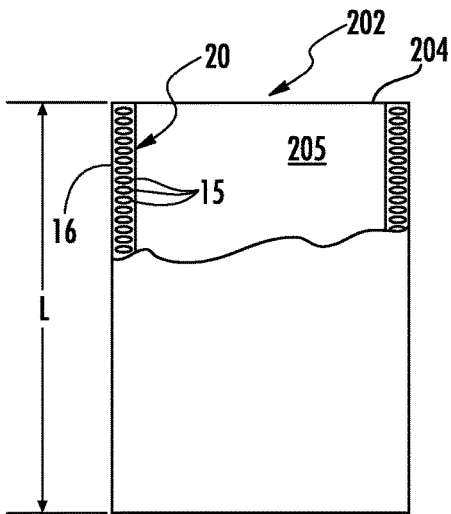

FIG. 10

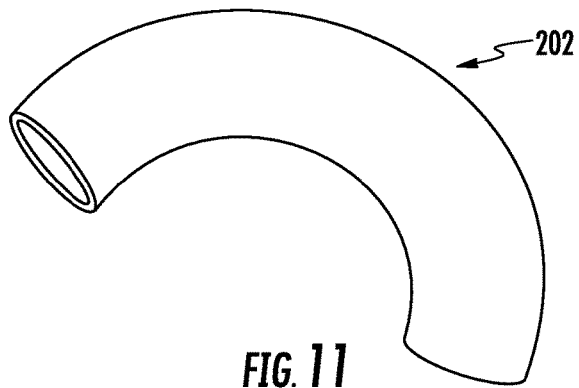

FIG. 11

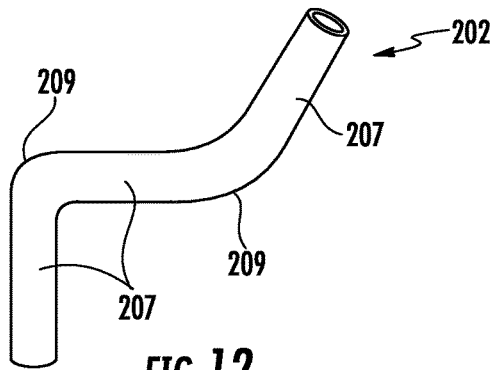

FIG. 12

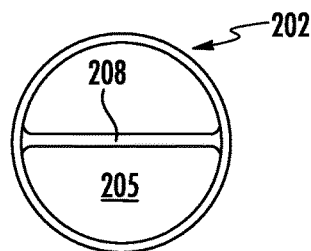

FIG. 13

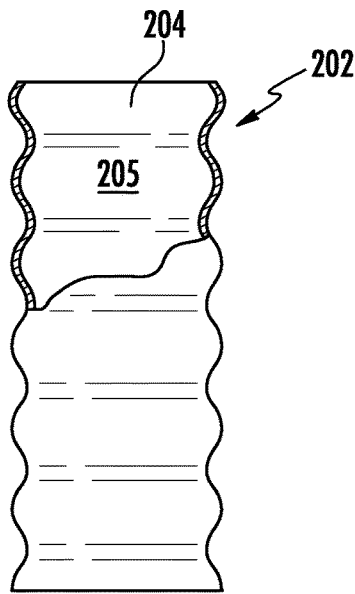

FIG. 14

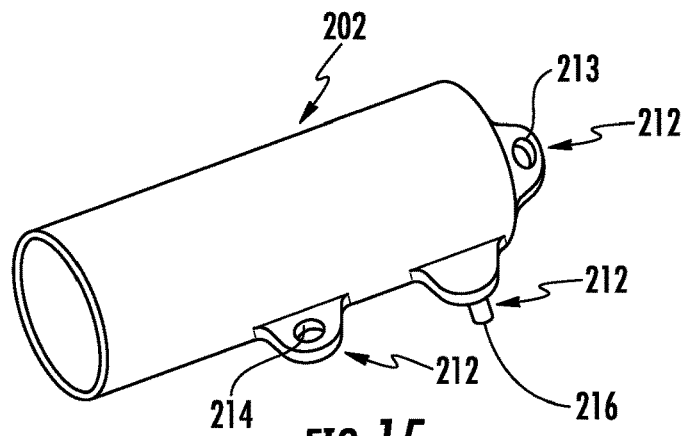

FIG. 15

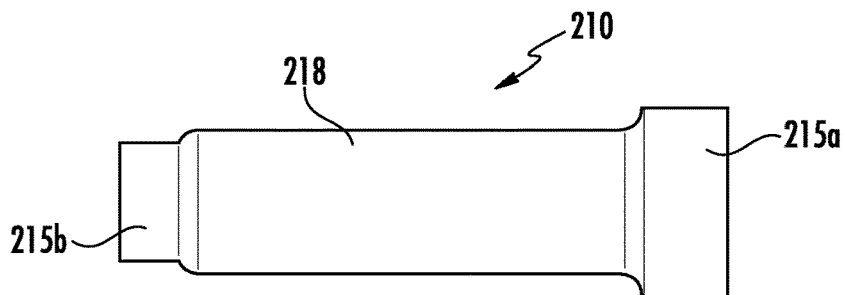

FIG. 16

### 3D PRINTED CONTINUOUS FIBER REINFORCED PART

#### CROSS-REFERENCE TO RELATED APPLICATION(S)

**[0001]** This application is a non-provisional of and claims priority to U.S. Provisional Application No. 62/478,132 filed on Mar. 29, 2017, of the same title, the contents of which are also incorporated herein by reference.

#### FIELD OF THE INVENTION

**[0002]** The present invention, in general, relates to a fiber reinforced part formed via an additive manufacturing process.

#### BACKGROUND OF THE INVENTION

**[0003]** Additive manufacturing refers to any method for forming a three-dimensional (“3D”) object in which successive layers of material are laid down according to a controlled deposition and solidification process. The main differences between additive manufacturing processes are the types of materials to be deposited and the way the materials are deposited and solidified. Fused deposition modeling (also commonly referred to as 3D printing) extrudes materials including liquids (e.g., polymeric melts or gels) and extrudable solids (e.g., clays or ceramics) to produce a layer, followed by spontaneous or controlled curing of the extrudate in the desired pattern of the structure layer. Other additive manufacturing processes deposit solids in the form of powders or thin films, followed by the application of energy and/or binders often in a focused pattern to join the deposited solids and form a single, solid structure having the desired shape. Generally, each layer is individually treated to solidify the deposited material prior to deposition of the succeeding layer, with each successive layer becoming adhered to the previous layer during the solidification process. While additive manufacturing technologies have become much more common and less expensive in recent years, the technology is primarily limited to formation of prototypes, as the formed materials generally exhibit low strength characteristics.

**[0004]** An object manufactured by an additive manufacturing process that has high strength characteristics is desired.

#### SUMMARY OF THE INVENTION

**[0005]** In some embodiments a part comprises a continuous fiber substantially encased in a formation material. The fiber and formation material are arranged in a plurality of alternating layers such that the formation material of a first one of the alternating layers adheres to the formation material of a second one of the alternating layers over the length of the continuous fiber.

**[0006]** The part may include a thin-walled hollow member such as a duct or a container, either fully or partially enclosed. The continuous fiber extends uninterrupted or substantially uninterrupted for the length of the reinforced part.

**[0007]** In some embodiments, the part is a duct which includes a thin reinforced wall having a first end and a second end and defining a hollow interior. The reinforced wall comprises a continuous fiber extending from the first end to the second end substantially encased in a formation

material. The fiber and formation material are arranged in a plurality of alternating layers such that the formation material of a first one of the alternating layers adheres to the formation material of a second one of the alternating layers over the length of the continuous fiber. The duct may include a non-reinforced portion formed of material that does not include a reinforcement fiber and/or a partially non-reinforced portion that includes portions that include a reinforced fiber and portions where such a fiber is absent.

**[0008]** In some embodiments a part comprising a continuous fiber prepared by an additive manufacturing process comprising the steps of: depositing a composite material on a print bed using a print head, the composite material comprising a continuous fiber and a formation material in intimate contact with the continuous fiber; moving the print head and/or the print bed during the depositing of the composite material; and consolidating the composite material.

#### BRIEF DESCRIPTION OF THE DRAWINGS

**[0009]** FIG. 1A shows a front view of an exemplary system having a print bed with 6 degrees of movement.

**[0010]** FIG. 1B shows a side view of the exemplary system of FIG. 1A.

**[0011]** FIG. 1C shows a top view of the exemplary system of FIG. 1A.

**[0012]** FIG. 1D shows a side view of a prototype set-up employing a mandrel connected with the print bed.

**[0013]** FIG. 2 illustrates a method for forming a composite filament as described herein.

**[0014]** FIG. 3 illustrates another method for forming a composite filament as described herein.

**[0015]** FIG. 4 illustrates an additive manufacturing method incorporating a composite filament as described herein.

**[0016]** FIGS. 5, 6 and 7 are perspective views of exemplary embodiments of a 3D printed fiber reinforced part.

**[0017]** FIG. 8 is a section view of a continuous fiber and composite material as it exits the nozzle prior to formation of the fiber reinforced part.

**[0018]** FIG. 9 is a magnified section view of another exemplary embodiment of a 3D printed fiber reinforced part.

**[0019]** FIGS. 10 and 14 are partial section views of still other exemplary embodiments of a 3D printed fiber reinforced part.

**[0020]** FIGS. 11, 12 and 15 are perspective views of exemplary embodiments of a 3D printed fiber reinforced part.

**[0021]** FIG. 13 is an end view of another exemplary embodiment of a 3D printed fiber reinforced part.

**[0022]** FIG. 16 is a side view of another exemplary embodiment of a 3D printed fiber reinforced part.

#### DETAILED DESCRIPTION OF THE INVENTION

**[0023]** Reference now will be made to the embodiments of the invention, one or more examples of which are set forth below. It will be apparent to those skilled in the art that various modifications and variations can be made in the invention without departing from the scope or spirit of the invention. For instance, features illustrated or described as one embodiment can be used on another embodiment to yield still a further embodiment.

[0024] The 3D printer as shown and described herein allows for printing of high strength composite parts with continuous fibers or filaments in multiple directions and orientations. The term “fiber” as used herein includes the composite filament described herein and means any continuous elongated piece of material that may be used to reinforce a high strength composite part as described herein.

[0025] FIGS. 1A-1C shows an exemplary system 10 including a nozzle or print head 12 having an extrusion tip 14 defining a translational point PT. The nozzle 12 combines a formation material 16 and a continuous fiber 18 to form a composite material 20. During printing, the composite material 20 is deposited onto the printing surface 22 of the print bed 24 and/or a mandrel located on the printing surface 22 (where the mandrel acts as a structural form to which the composite material is applied), and/or an existing work piece. The print bed 24 is moveable, independently with 6 degrees of freedom, as controlled by the controller 26. As will be discussed later, the movement/orientation of an optional mandrel 32 (FIG. 1D) may also be controlled relative to the print bed to provide added degrees of freedom for further complex printing.

[0026] The print bed 24 is moveable in the x-direction (i.e., up/down with respect to the translational point PT), in the y-direction (i.e., laterally with respect to the translational point PT), and z-direction (i.e., cross-laterally with respect to the translational point PT). The print bed 24 can be moved translational, independently, by controller 26 using the arm 28 connected to the receiver 30 of the print bed 24. In particular embodiments, the arm 28 can be formed from multiple segments connected together at moveable joints (bending and/or rotating) to allow for translational movement of the print bed 24 with respect to the translation point PT.

[0027] Additionally, the print bed 24 is rotationally moveable about the rotational point PR to allow roll (r), pitch (p), and yaw (w) rotational movement. The print bed 24 can be rotated in any direction, independently, by controller 26 using the arm 28 connected to the receiver 30 of the print bed 24. Although shown as utilizing a rotation ball 29 coupled to the receiver 30, any suitable connection can be utilized.

[0028] As shown in FIG. 1D, in some embodiments, a mandrel 32 may be applied to the printing surface 22 of the print bed 24. The mandrel 32 may act as a structural form to which the fiber(s) and/or composite materials are applied to form the work piece. In some embodiments, the mandrel 32 may be applied in a stationary manner to the printing surface and move with the print bed 24 of the printer. In some embodiments, the mandrel may be applied to a second printing surface or positioned on a moveable arm that is separate from the print bed 24, so that the mandrel is moveable relative to the print bed 24 to create further degrees of freedom beyond the six degrees of freedom achieved via the movable print bed. Alternatively, added degrees of freedom could be achieved via use of multiple print beds that are each movable in six degrees of freedom relative to the base print bed 24, whereby controlled orientation of the base print bed 24 and controlled orientation of the added print beds creates further degrees of freedom.

[0029] In one embodiment, the controller 26 may comprise a computer or other suitable processing unit. Thus, in several embodiments, the controller 26 may include suitable computer-readable instructions that, when implemented, configure the controller 26 to perform various different

functions, such as receiving, transmitting and/or executing arm movement control signals.

[0030] A computer generally includes a processor(s) and a memory. The processor(s) can be any known processing device. Memory can include any suitable computer-readable medium or media, including, but not limited to, RAM, ROM, hard drives, flash drives, or other memory devices. The memory can be non-transitory. Memory stores information accessible by processor(s), including instructions that can be executed by processor(s). The instructions can be any set of instructions that when executed by the processor (s), cause the processor(s) to provide desired functionality. For instance, the instructions can be software instructions rendered in a computer-readable form. When software is used, any suitable programming, scripting, or other type of language or combinations of languages may be used to implement the teachings contained herein. Alternatively, the instructions can be implemented by hard-wired logic or other circuitry, including, but not limited to application-specific circuits. Memory can also include data that may be retrieved, manipulated, or stored by processor(s).

[0031] The computing device can include a network interface for accessing information over a network. The network can include a combination of networks, such as Wi-Fi network, LAN, WAN, the Internet, cellular network, and/or other suitable network and can include any number of wired or wireless communication links. For instance, computing device could communicate through a wired or wireless network with the arm 28, the rotation ball 29, and/or the nozzle 12.

[0032] In one embodiment, the printer can include multiple nozzles or print heads. For example, a nozzle can be included to print wax-like material to support the formation material during the printing process.

[0033] In one particular embodiment, the controller 26 can include (or be in communication with a computer that includes) supporting software programs that can include, for example, computer aided design (CAD) software and additive manufacturing layering software as are known in the art. The controller 26 can operate via the software to create a three-dimensional drawing of a desired structure and/or to convert the drawing into multiple elevation layer data. For instance, the design of a three-dimensional structure can be provided to the computer utilizing commercially available CAD software. The structure design can then be sectioned into multiple layers by commercially available layering software. Each layer can have a unique shape and dimension. The layers, following formation, can reproduce the complete shape of the desired structure.

[0034] For example, the printer can be accompanied with software to slice beyond the current xyz slicing methodology used in industry. For example, 3D objects other than 3D Cartesian objects, such as an iso-parametric helically/spirally wound band around a duct, can be spirally sliced instead of sliced in a flat plane, to be able to spirally lay-down/print filament and/or slit tape/tow. Thus, the iso-parametric slicing can be utilized with printing capability of the 6 degrees of freedom.

[0035] In a traditional 3D printing system, the layer files are translated to print head movements for applying material to a print bed to form the work piece. In the print system provided herein, the layer files are also translated to print bed and/or mandrel movements to create the various layers

and continuous thread patterns discussed herein via movement of the print head and/or the mandrel.

**[0036]** Numerous software programs have become available that are capable of performing the presently specified functions. For example, AUTOLISP can be used to convert AUTOCAD drawings into multiple layers of specific patterns and dimensions. CGI (Capture Geometry Inside, currently located at 15161 Technology Drive, Minneapolis, Minn.) also can provide capabilities of digitizing complete geometry of a three-dimensional object and creating multiple-layer data files. The controller **26** can be electronically linked to mechanical drive means so as to actuate the mechanical drive means in response to “x,” “y,” and “z” axis drive signals and “p,” “r,” and “w,” rotation signals, respectively, for each layer as received from the controller **26**.

**[0037]** As stated, the composite material **20** includes a formation material **16** and a continuous fiber **18**. The continuous fiber **18** is discharged in conjunction with the formation material **16** such that the continuous fiber **18** is at least partially encased within the formation material **16** to form the composite material **20**, as shown. In some embodiments the continuous fiber **18** is completely encased in the formation material **16**. The formation material **16** can be a metal, a polymeric material, etc. that is fed to the nozzle **12** and is heated above the melting temperature of the material to soften and/or liquefy so as to flow through the extrusion tip **14** and form a partial or continuous coating on the continuous fiber **18**, such that the formation material bonds with the outer surface of the continuous fiber.

**[0038]** The formation material **16** can be, for example, a gel, a high viscosity liquid, or a formable solid that can be extruded in the desired pattern. Formation materials likewise can be organic or inorganic. Formation materials can include, without limitation, polymers including thermoplastic polymers or thermoset polymers (e.g., polyolefins, polystyrenes, polyvinyl chloride, elastomeric thermoplastics, polycarbonates, polyamides, etc.), eutectic metal alloy melts, clays, ceramics, silicone rubbers, and so forth. Blends of materials can also be utilized as the formation materials, e.g., polymer blends. The formation materials can include additives as are generally known in the art such as, without limitation, dyes or colorants, flow modifiers, stabilizers, nucleators, flame retardants, and so forth.

**[0039]** The formation material is combined with a high strength continuous fiber(s) **18** prior to or during formation of the layer. The high strength continuous fibers can be utilized as individual fibers or as bundles of fibers, e.g., a roving. As used herein, the term “roving” generally refers to a bundle or tow of individual fibers. The fibers contained within the roving can be twisted or can be straight. Although different fibers can be used in a roving, it can be beneficial in some embodiments, if a roving contains a single fiber type to minimize any adverse impact of using fiber types having a different thermal coefficient of expansion. The number of fibers contained in each roving can be constant or vary from roving to roving and can depend upon the fiber type. A roving can include, for instance, from about 500 fibers to about 100,000 individual fibers, or from about 1,000 fibers to about 75,000 fibers, and in some embodiments, from about 5,000 to about 50,000 fibers.

**[0040]** The continuous fibers possess a high degree of tensile strength relative to their mass. For example, the ultimate tensile strength of the fibers can be about 3,000 MPa or greater. For instance, the ultimate tensile strength of

the fibers as determined according to ASTM D639 (equivalent to ISO testing method 527) is typically from about 3,000 MPa to about 15,000 MPa, in some embodiments from about 4,000 MPa to about 10,000 MPa, and in some embodiments, from about 5,000 MPa to about 6,000 MPa. Such tensile strengths may be achieved even though the fibers are of a relatively light weight, such as a mass per unit length of from about 0.1 to about 2 grams per meter, in some embodiments from about 0.4 to about 1.5 grams per meter. The ratio of tensile strength to mass per unit length may thus be about 2,000 Megapascals per gram per meter (“MPa/g/m”) or greater, in some embodiments about 4,000 MPa/g/m or greater, and in some embodiments, from about 5,500 to about 30,000 MPa/g/m.

**[0041]** The high strength fibers may be organic fibers or inorganic fibers. For example, the high strength fibers may be metal fibers (e.g., copper, steel, aluminum, stainless steel, etc.), basalt fibers, glass fibers (e.g., E-glass, A-glass, C-glass, D-glass, AR-glass, R-glass, S1-glass, S2-glass, etc.), carbon fibers (e.g., amorphous carbon, graphitic carbon, or metal-coated carbon, etc.), nanotubes, boron fibers, ceramic fibers (e.g., boron, alumina, silicon carbide, silicon nitride, zirconia, etc.), aramid fibers (e.g., Kevlar® marketed by E. I. duPont de Nemours, Wilmington, Del.), synthetic organic fibers (e.g., polyamide, ultra-high molecular weight polyethylene, paraphenylene, terephthalamide, and polyphenylene sulfide), polybenzimidazole (PBI) fibers, and various other natural or synthetic inorganic or organic fibrous materials known for reinforcing compositions. The materials used to form the fibers can include various additives as are known in the art, e.g., colorants, etc.

**[0042]** Carbon fibers are particularly suitable for use as the continuous fibers, which typically have a tensile strength to mass ratio in the range of from about 5,000 to about 7,000 MPa/g/m.

**[0043]** The continuous fibers can generally have a nominal diameter of about 2  $\mu\text{m}$  micrometers or greater, for instance about 4  $\mu\text{m}$  to about 35  $\mu\text{m}$  (micrometers or microns), and in some embodiments, from about 5  $\mu\text{m}$  to about 35  $\mu\text{m}$  micrometers.

**[0044]** The continuous fibers are discharged in conjunction with the formation material during the formation of an individual layer of the additively manufactured product structure such that the continuous fiber is at least partially encased by the formation material. Any suitable method for combining the materials can be utilized, provided that the continuous fiber is adequately incorporated with the formation material and bonding between the two materials can occur. The type of bond formed between the continuous fiber and the formation material can depend upon the two materials involved. For instance a thermal bond, a chemical bond, a friction bond, an electrostatic bond, etc. can be formed between the two materials in order that the high strength continuous fiber is at least partially encased by the formation material and the two components will be effectively bonded to one another. In some embodiments, both the continuous fiber and the formation material may be sufficiently heated to promote admixing of the formation material and continuous fiber to form the composite material.

**[0045]** As will be appreciated from this disclosure, the continuous fiber may be any material having reinforcing characteristics. The continuous fiber may be formed of a plurality of fibers of either the same or differing materials. The formation material may be formed of one material or an

admixture of multiple materials. Further, the print head may be configured to apply one or multiple coatings of formation material on the continuous fiber, either stacked on the other, overlapping or applied at different positions on the surface of the continuous fiber. Further, the print head could be configured to advance several different continuous fibers with different or the same formation materials, depending on the specifications required for formation of a work piece. In addition, the system could include multiple print heads configured to provide either the same or different print media to a work piece, so that different compositions of materials may be used to form the work piece. For example, some print heads could be configured to either advance different continuous fibers and/or formation materials to provide different composition materials to be selectively applied to the work piece. In further or alternative embodiments, some print heads may be configured to provide continuous fiber reinforced composite materials, while other print heads provide non-reinforced printing media to thereby provide a work piece that has selective reinforced sections.

**[0046]** Discharge of the continuous fiber from the print head can be achieved in different manners, depending on the application. In one embodiment, the continuous fiber may be advanced through the print head as part of an extrusion process, whereby the continuous fiber is “pushed” or urged through the print head. In this embodiment, the continuous fiber is engaged with a driving system, such as a motorized friction drive wheel(s) or a forced air system, to advance the continuous fiber through the print head. The continuous fiber enters an input orifice in the print head and is advanced toward the extrusion tip **14** of the nozzle **12**. The formation material **16** is heated above the melting temperature of the formation material to soften and/or liquefy so as to flow through the extrusion tip **14** and form at least a partial coating on the continuous fiber **18**, as the continuous fiber is advanced from the print head and onto the printing surface **22**, a mandrel **32**, and/or an existing work piece on the print bed **24**. By movement of the print bed **24** and/or the mandrel relative to the print head, work pieces can be formed by additive application of the composite material **20** onto the printing surface **22**, mandrel, and/or existing work piece.

**[0047]** As an alternative to advancing the continuous fiber by push or urging the fiber through the print head, the continuous fiber may be advanced by a pultrusion operation, whereby the continuous fiber is drawn or pulled from the tip of the nozzle. In this embodiment, the contact point of the composite material on the printing surface **22** of the print bed **24**, an alternative mandrel **32** located on the print bed **24**, and/or an existing work piece located on the print bed creates an anchor (e.g., a fixed, contact, gripping point, and the like) that allows for the composite material **20** to be pulled from the print head as the print bed **24**, mandrel **32**, and/or existing work piece is moved relative to the print head to form the finished work piece. In this embodiment, using the movement of the print bed and/or mandrel allows for precise control of the advancement of the composite material **20** from the print head.

**[0048]** Drawing or “casting on” of the composite material **20** onto the printing surface **22**, mandrel **32** and/or existing work piece to begin the printing process can be accomplished by various methods. For example, the composite material **20** could be connected or adhered to a needle or other type structure that can draw the composite material from the print head and apply it to the printing surface,

mandrel, and/or existing work piece. As an alternative, the nozzle of the print head may be brought into contact with the printing surface **22** of the print bed **24**, the mandrel **32**, and/or the existing work piece so as to contact the composite material **20**, whereby either the composite material itself or the formation material **16** surrounding the continuous fiber **18** in the melted state adheres to the printing surface **22**, mandrel **32**, and/or the existing work piece creating an anchor for pulling the composite material **20** from the print head.

**[0049]** The rate of advancement of the continuous fiber through the print head, the temperature of the formation material, and/or in some instances, the temperature of the printing surface **22** of the print bed **24**, the mandrel **32**, and/or the existing work piece on the print bed require some level of control to ensure that the continuous fiber **18** receives a consistent/desired coating and that the composite material **20** is applied to either the printing surface **22**, mandrel **32**, and/or existing work piece in a manner to adhere to same. For example, the temperature of the formation material **16** and the rate of movement of the print bed and/or mandrel may be controlled to ensure that the composite material **20** is applied in a manner to allow for proper adherence of the composite material **20** to the printing surface **22**, mandrel **32**, and/or existing work piece. In some instances, the printing surface and/or the mandrel and/or the existing work piece on which the composite material **20** is applied can also or alternatively be temperature controlled for this purpose. In general, the rate of application and temperature of the formation material **16** on the continuous fiber **18** are controlled to ensure that the coating is applied in a desired manner on the continuous fiber and that the composite material **20** is drawn from the print head in a consistent manner.

**[0050]** Tensioning of the composite material may also be required for proper advancement onto the printing surface, mandrel, and/or existing work piece. Tensioning systems can take many forms and be located at different positions in the process to provide proper tensioning of the continuous fiber and/or the composite material. For example, a spool maintaining the continuous fiber could be fitted on a tensioning system, such as a rotational break or clutch that impedes rotation of the spool as continuous fiber is metered from the spool to provide tensioning. Similarly, the print head may include a tensioning system, such as restrictive pulleys, clutch, friction element or the like to apply tension to the continuous fiber.

**[0051]** It is also contemplated that the proposed printer could be equipped to perform both “push” and pultrusion of the continuous fiber to advance the continuous fiber through the print head. In this embodiment, there may be drive means associated with the print head to advance the continuous fiber through the print head assisted by a pulling effect of the movement of the print bed, mandrel, and/or existing work piece on the composite material as it is advanced.

**[0052]** As mentioned above, in some embodiments, the composite material **20** may be applied to a mandrel, where the mandrel operates as a form, support and/or pattern of the work piece to be manufactured from the composite material **20**. The mandrel aids in shaping of the work piece being printed as the composite material is applied to the mandrel. After printing is complete, and the printed work piece has at least partially cured, the mandrel can be removed from the

work piece, such as by eroding, dissolving, breakings, shrinking, or other contemplated procedures for removing either portions of or the entire mandrel.

**[0053]** The above description discloses an embodiment of the system that incorporates both a print head capable of advancing a continuous fiber and a print bed that is moveable with six degrees of freedom. It is understood, however, that embodiments are contemplated whereby a print head capable of advancing a continuous fiber may be incorporated into a system that comprises a stationary print bed. Alternatively, embodiments are contemplated whereby a system is employed that includes a print bed that is moveable with six degrees of freedom in combination with a traditional 3D print head that does not advance a continuous fiber.

#### EXAMPLES

**[0054]** A prototype set-up was developed that includes a 6 degrees of freedom robot with integrated industrial level controls to operate the extruder (print head), hotbed and temperature sensors. Integration of hardware and software has been achieved. A KUKA KR6 based robotic system was developed to print thin walled continuous carbon reinforced ULTEM ducting for use in vehicles. The system allows printing of carbon fiber reinforced ULTEM of thin walled ducts with fibers printed not only in the plane of the cross-section of the duct but also in directions with angles with respect to the cross-sectional plane. This is in contrast to current 3D printing systems based on printing layer by layer and therefore allowing only fibers in the cross-sectional plane. The system may offer seven (7) degrees of freedom (3 translations and 3 rotations related to the robot and 1 degree of freedom imparted by a separate mandrel). The system is fed with a material system compliant to the Fire, Smoke and Toxicity (FST) requirements specified by FAA and EASA. The system has multiple printing heads to be able to print parts that are designed to be built from a combination of unreinforced, chopped fiber reinforced and continuous fiber reinforced materials. In addition a printing head is supplied able to print support material that can be removed after printing. This support material serves as an optional stabilizer for long, thin walled parts.

**[0055]** The 3D printer is particularly suitable for printing ready-for-use duct work, conduit, tubing, piping, channeling, hollow-chambered structures and other similar structures by addressing the stiffness and strength shortcomings that would be associated with forming these parts with a conventional 3D printing technique, which would provide unreinforced polymer 3D printed parts. As an example, the provided 3D printer can be used in applications to print thin-walled, complex shaped parts, which, heretofore could only be manufactured in a complex, multi-step process. Thus, the provided 3D printer and processes allows the 3D printing of multi-axial composite parts with multiple degrees of print freedom, opening the possibility of printing high performance parts with the continuous fiber reinforcement creating the required stiffness and strength.

**[0056]** In some embodiments a continuous composite filament may be used as the continuous fiber. The composite filament allows for formation of work pieces having a complicated shape that can incorporate continuous filaments in multiple directions and orientations, which can lead to the production of stronger and more useful composite structures. In particular, the composite filaments can combine the strength and stiffness of continuous filaments (e.g., carbon

tows) with the formation flexibility of additive manufacturing formation materials to provide a composite filament capable of successful deposition according to an additive manufacturing process.

**[0057]** The composite filament as described herein is particularly suitable for use as a continuous fiber for the formation of structures for use in high performance environments, e.g., environments operating under high thermal, chemical, and/or mechanical stresses. Examples of encompassed products commonly found in such environments can include, without limitation, duct work, conduit, tubing, piping, channeling, hollow-chambered structures and other similar structures. In such high performance embodiments, the composite filaments can include a high-strength continuous filament in conjunction with a high performance polymer, and in one particular embodiment with a thermoplastic polymer that exhibits a high glass transition temperature. Such composite filaments can be utilized in an additive manufacturing process and address the stiffness, strength, and environmental performance shortcomings (e.g., thermal resistance) that would be associated with forming such parts with conventional techniques and materials. For instance, conventional additive manufacturing techniques can provide only unreinforced polymer parts. As an example, the composite filaments can be used in applications to 3D print thin-walled, complex-shaped reinforced parts that heretofore could only be manufactured in a complex, multi-step process. Thus, the composite filaments can allow the formation of continuous filament reinforced composite parts having complicated geometries and exhibiting high performance characteristics formed according to an additive manufacturing process.

**[0058]** FIG. 2 schematically illustrates one method for forming a composite filament usable as a continuous fiber in the additive manufacturing process described herein. The method can include immersing a continuous filament **108** into a solution **102** that includes a polymer in a dissolved state and a solvent for the polymer.

**[0059]** While the composite filaments can incorporate any continuous filament **108** as is known in the art, in particular embodiments the continuous filament **108** can be a high strength, high performance continuous filament. The high strength continuous filament **108** can be utilized as an individual filament (e.g., as a porous or shaped filament that can be permeated with the polymer solution) or as a bundle of individual filaments or filaments, e.g., a roving. As used herein, the term "roving" generally refers to a bundle of generally aligned individual filaments and is used interchangeably with the term "tow." The individual filaments contained within the roving can be twisted or can be straight and the bundle of individual filaments can be twisted about one another or generally parallel continuous filaments with no intentional twist to the roving. Although different filaments can be used in a roving, it can be beneficial in some embodiments to utilize a roving that contains a plurality of a single filament type, for instance to minimize any adverse impact of using filament types having a different thermal coefficient of expansion. The number of filaments contained in a roving can be constant or vary from one portion of the roving to another and can depend upon the material of the filament. A roving can include, for instance, from about 500 individual filaments to about 100,000 individual filaments, or from about 1,000 individual filaments to about 75,000

individual filaments, and in some embodiments, from about 5,000 individual filaments to about 50,000 individual filaments.

**[0060]** The continuous filament **108** can possess a high degree of tensile strength relative to the mass. For example, the ultimate tensile strength of a continuous filament **108** can be about 3,000 MPa or greater. For instance, the ultimate tensile strength of a continuous filament **8** as determined according to ASTM D639 (equivalent to ISO testing method 527) is typically from about 3,000 MPa to about 15,000 MPa, in some embodiments from about 4,000 MPa to about 10,000 MPa, and in some embodiments from about 5,000 MPa to about 6,000 MPa. Such tensile strengths may be achieved even though the filaments are of a relatively light weight, such as a mass per unit length of from about 0.1 to about 2 grams per meter, in some embodiments from about 0.4 to about 1.5 grams per meter. The ratio of tensile strength to mass per unit length may thus be about 2,000 Megapascals per gram per meter ("MPa/g/m") or greater, in some embodiments about 4,000 MPa/g/m or greater, and in some embodiments, from about 5,500 to about 30,000 MPa/g/m.

**[0061]** A continuous filament **108** may be an organic filament or an inorganic filament. For example, a continuous filament **108** may include a metal (e.g., copper, steel, aluminum, stainless steel, etc.), basalt, glass (e.g., E-glass, A-glass, C-glass, D-glass, AR-glass, R-glass, S1-glass, S2-glass, etc.), carbon (e.g., amorphous carbon, graphitic carbon, or metal-coated carbon, etc.), nanotubes, boron, ceramics (e.g., boron, alumina, silicon carbide, silicon nitride, zirconia, etc.), aramid (e.g., Kevlar® marketed by E. I. duPont de Nemours, Wilmington, Del.), synthetic organics (e.g., polyamide, ultra-high molecular weight polyethylene, paraphenylene, terephthalamide, and polyphenylene sulfide), polybenzimidazole (PBI) filaments, and various other natural or synthetic inorganic or organic materials known for forming fibrous reinforcing compositions. However, the continuous filament should be formed of materials having a melting temperature greater than the deposition temperature of the additive manufacturing process in which the composite filaments will be used and greater than the thermoplastic polymer that will be combined with the continuous filament in forming the composite filament. The materials used to form the filaments can include various additives as are known in the art, e.g., colorants, etc.

**[0062]** Carbon filaments are particularly suitable for use as the continuous filaments in one embodiment. Carbon filaments can typically have a tensile strength to mass ratio in the range of from about 5,000 to about 7,000 MPa/g/m.

**[0063]** The continuous filaments can generally have a nominal diameter of about 2 micrometers or greater, for instance about 4 to about 35 micrometers, and in some embodiments, from about 5 to about 35 micrometers.

**[0064]** Referring again to FIG. 2, a continuous filament **108** can be immersed in a solution **102** that includes a polymer dissolved in a solvent. For instance, the continuous filament **108** can be pulled through a bath of the solution by use of a series of rollers **103**, as shown. While the composite filament can generally incorporate any polymer that may be successfully associated with the continuous filament **108**, in one embodiment the polymer can be a high performance thermoplastic polymer or a thermoset polymer. High performance polymers as may be incorporated in the composite filament can include, without limitation, amorphous thermoplastics such as polysulfone (PSU), poly(ethersulfone)

(PES), and polyetherimide (PEI), as well as semi-crystalline thermoplastics such as poly(phenylene sulfide) (PPS), polyarylether ketones (PAEK) including polyether ketones (PEK) and polyetheretherketone (PEEK), partly aromatic polyamides such as polyphthalamide (PPA), liquid-crystalline polymers (LCP), polyphenylene sulfones (PPSU), as well as blends and copolymers of thermoplastics.

**[0065]** Suitable thermoset polymers can include, without limitation, epoxy resins, silicone resins, polyimides, phenol-formaldehyde resin, diallyl phthalate, as well as combinations of materials. It will be understood by one of ordinary skill in the art that when considering utilization of a thermoset polymer in formation of the composite filament, it may be beneficial to encourage final cure of the polymer following the additive manufacturing process, so as to improve consolidation of the composite filament in the manufactured structure.

**[0066]** In one particular embodiment, a thermoplastic polymer that exhibits a high glass transition temperature ( $T_g$ ) can be incorporated in the composite filament. For instance, a thermoplastic polymer having a glass transition temperature of about 150° C. or greater can be dissolved in the solution **2**. Exemplary high  $T_g$  polymers can include, without limitation, polyethyleneimine ( $T_g=215^\circ$  C.), PEI ( $T_g=217^\circ$  C.), polyamide-imide ( $T_g=275^\circ$  C.), polyarylate ( $T_g=190^\circ$  C.), PES ( $T_g=210^\circ$  C.- $230^\circ$  C.), polyimide ( $T_g=250^\circ$  C.- $340^\circ$  C.), polyphenylene ( $T_g=158^\circ$  C.- $168^\circ$  C.), and amorphous thermoplastic polyimide ( $T_g=247^\circ$  C.). Other examples of high  $T_g$  polymers include those that contain one or more of the following monomers (listed along with a published  $T_g$  for the homopolymer): 2-vinyl naphthalene ( $T_g=151^\circ$  C.), 2,4,6-trimethylstyrene ( $T_g=162^\circ$  C.), 2,6-dichlorostyrene ( $T_g=167^\circ$  C.), vinyl carbazole ( $T_g=227^\circ$  C.), vinyl ferrocene ( $T_g=189^\circ$  C.); acenaphthalene ( $T_g=214^\circ$  C.), and methacrylic acid anhydride ( $T_g=159^\circ$  C.).

**[0067]** The solution can include a solvent for the polymer, which can encompass organic or aqueous solvents, as determined according to the characteristics of the polymer. For instance, a solution can include PEI in solution with a suitable solvent, e.g., methanol, ethanol, or chloroform, as is known in the art. The solution can generally include the polymer in an amount of about 20 wt. % or less, for instance about 10 wt. % or less in some embodiments.

**[0068]** As illustrated in FIG. 2, as the continuous filament **108** is pulled or otherwise immersed in the solution **102**, the filament **108** can pick up polymer contained in the solution to form a wet composite filament **109**. Following, the wet composite filament **109** can be dried to remove the solvent and form the composite filament **118**. For instance, the wet composite filament **109** can be dried through application of energy, e.g., through use of a dryer **107**.

**[0069]** The composite filament formation process can include additional formation steps in some embodiments. For instance, as illustrated in FIG. 3, a process can include a series of nip rolls **5** or the like that can improve impregnation of the dissolved polymer into the filament **8**.

**[0070]** In one embodiment, a formation process can include a die **113** through use of which the composite filament **118** can be further formed or molded. For instance, the initially formed composite filament **118** can be fed through a die **113** to mold the filament and modify the cross-sectional shape of the composite filament **118** and provide a particular and/or more consistent shape of the composite filament **118**. Depending upon the nature of the



die 113, it may prove beneficial to incorporate a second dryer 107 or the like downstream of the die 113.

[0071] FIG. 4 illustrates one embodiment of an additive manufacturing process as may be utilized to form a structure incorporating the continuous composite filament is the continuous fiber and is similar to the embodiment of FIGS. 1A-1D. As shown, the composite filament 118 can be combined with a formation material 126. In this embodiment, the formation material 126 can be provided to a print head 112 in the form of a second filament. For instance, the formation material 126 can be a metal, a polymeric material, etc. that is fed to the print head 112 and is heated above the melting temperature of the formation material 126 to soften and/or liquefy so as to be combined with the composite filament 18 within the print head 112. The composite filament 118 is likewise heated to a temperature above the melting temperature of the polymer of the composite. Upon combination of the formation material 126 with the composite filament 118 within the print head 112, the formation material 126 can blend and/or bond with the polymer of the composite filament 118 and the formation material 126 can form a partial or continuous coating on the composite filament 18 to form the composite material 116. The composite material 116 thus formed can pass through the extrusion tip 114 to the printing surface 122.

[0072] The formation material may be formed of one material or an admixture of multiple materials. The formation material 126 can be, for example, a gel, a high viscosity liquid, or a formable solid that can be extruded in the desired pattern. Formation materials likewise can be organic or inorganic. Formation materials can include, without limitation, polymers including thermoplastic polymers or thermoset polymers (e.g., polyolefins, polystyrenes, polyvinyl chloride, elastomeric thermoplastics, polycarbonates, polyamides, etc.), eutectic metal alloy melts, clays, ceramics, silicone rubbers, and so forth. Blends of materials can also be utilized as the formation materials, e.g., polymer blends. The formation materials can include additives as are generally known in the art such as, without limitation, dyes or colorants, flow modifiers, stabilizers, nucleators, flame retardants, and so forth.

[0073] In one particular embodiment, the formation material 126 can include the same polymer as the polymer of the composite filament 18. For instance, the composite filament 118 can include a continuous filament and a high T<sub>g</sub> thermoplastic polymer, such as PEI, and the formation material 126 can likewise include PEI. This can improve blending and bonding of the materials in the print head in formation of the composite material 116.

[0074] The composite material 116 can be discharged from the print head 112 onto surface 22 during the formation of an individual layer of an additively manufactured product structure. Any suitable method for combining the composite filament 118 and the formation material 126 can be utilized, provided that the continuous filament of the composite filament 18 is adequately incorporated with the formation material 126 following deposition. The type of bond formed between the composite filament 18 and the formation material 126 can depend upon the materials involved. For instance a thermal bond, a chemical bond, a friction bond, an electrostatic bond, etc., as well as combinations of bond types can be formed between the continuous filament and the polymer of the composite filament 118 and between either or both of these components of the composite filament

118 and the formation material 126 in order that the components will be effectively bonded to one another.

[0075] Various embodiments of a 3D-printed fiber reinforced part 202 are shown in FIGS. 5 through 7. In one embodiment the part 202 comprises a relatively thin-walled generally tubular member suitable for use as a duct or other conduit. The material of the part 202 comprises a composite material including a formation material and a continuous fiber (FIGS. 8-10). The parts shown and described herein may be advantageously made by the processes, devices and systems described above.

[0076] In some embodiments, the part 202 has a relatively thin-walled construction having a generally tubular shape. In one embodiment the part 202 is a duct such as an air duct suitable for use in aircraft although the duct may be used in any application or device. The part 202 may also be a pipe, conduit, sheath or the like. The part 202 may be produced in any suitable length L. In one embodiment the tubular part comprises a substantially enclosed wall 204 defining a generally hollow interior 205 that is open at either end. While the wall 204 is generally closed openings may be formed in wall 204. Moreover, the interior 205 may be closed at one or both ends. The wall 204 may have a generally annular or circular shape in cross-section as shown in FIGS. 5 and 7. In other embodiments the part may have other cross-sectional shapes such as, but not limited to, oval, rectangular, polygon, ellipse, stadium (FIG. 6) or the like. Moreover, a single part may have a cross sectional shape that varies in shape and/or dimensions over its length L. For example, as shown in FIG. 7 the part 202 tapers from a larger diameter to a smaller diameter over its length. The term "tubular" as used herein means any relatively thin walled member having a substantially closed wall defining a generally hollow interior that defines a cavity or passage regardless of the cross-sectional shape of the wall. The cross-sectional dimensions of the part 202 and the thickness of the wall 204 may vary. Moreover, while part 202 is shown as being relatively straight in the length L direction, the part 202 may be curved (FIG. 11) or be formed with linear sections 207 connected at curved or angled elbows 209 (FIG. 12).

[0077] While the interior is generally hollow the interior may comprise reinforcement members or braces 208 in the interior space 205, FIG. 13. Moreover, while the wall is shown as having a generally planar surface in cross-section, the wall may have surface variations such as a corrugated, ribbed or other surface, FIG. 14. Moreover the exterior surface or the interior surface of the wall may be formed with integral connection mechanisms 212 for connecting the member to a support surface or other structure, FIG. 15. The connection mechanisms 212 may comprise flanges or similar extensions defining through holes 213, threaded holes 214, grooves, or other openings for receiving separate fasteners. The connection mechanisms may also be formed as threaded members, posts, flats, snap-fit connectors or other structures 216 for engaging mating structures on another, part, structure, surface or the like. Because the part 202 is made by a 3D printing process as described above, the braces 208 and connection mechanisms 212 may be formed integrally with the part 202 in a one-piece unitary part.

[0078] A fitting or connection part 210 for connecting two or more of the parts 202 is shown in FIG. 16. The fitting 210 may comprise a generally tubular member having a coupling section 215a, 215b formed at one or both ends of a body

portion **216**. The coupling section **215a**, **215b** is configured to closely receive or be closely received in the end of a tubular part **202**. The shape of the coupling section **215a**, **215b** may be the same shape as the end of the tubular part **202** to which it is attached and may have internal dimensions that are slightly larger than the external dimension of the tubular member **215a** or external dimensions that are slightly smaller than the internal dimension of the tubular member **215b** such that the tubular part **202** and coupling section **215a**, **215b** are in close engagement with one another over their entire periphery. The body portion **214** of the fitting may have a different cross-sectional shape and/or size than the coupling sections **215a**, **215b** or the tubular part **202** to which the fitting is attached. Any of the tubular parts **202** may be provided with the coupling sections **215a**, **215b** such that the tubular members may be connected directly to one another. The fittings **210** and tubular parts **202** may be joined together using a friction fit, adhesive, chemical bonding, melt, solder, welding, mechanical fastener or other connector. While the examples shown herein are of a general tubular nature, it is understood that other shapes/configurations are possible and that these are only examples. For example, the part could be a closed or partially enclosed container having an inner chamber surround by side, top, and bottom walls, with or without one or more openings.

**[0079]** To more clearly describe the structure of a part made as described above reference is made to FIGS. **8** and **9**. FIG. **8** shows a cross-section of a composite material as it is discharged from the nozzle during the formation process. The composite material comprises a continuous fiber **302** encased in a formation material **304** as previously described. The continuous fiber **302** exits the print head with a substantially circular cross-section and is substantially uniformly encased in the formation material **304** such that the layer of formation material, as it is discharged from the nozzle, has a substantially annular shape in cross-section. While the fiber has a generally circular cross section and the formation material has a generally annular cross-section, it will be appreciated that both the fiber and surrounding layer of formation material have surface irregularities and do not form perfect geometric shapes. Moreover, in some embodiments the fiber may have other than a circular cross-section.

**[0080]** In one example embodiment, the diameter  $D$  of the fiber may be in the range of 500 to 800  $\mu\text{m}$  (micron). The total diameter  $TD$  of the fiber encased in formation material may be in the range of 800 to 1200  $\mu\text{m}$ . These ranges may be adjusted to whatever is desired for a particular product. The thickness  $T$  of the layer of formation material may be in the range of 0 to 400  $\mu\text{m}$  on the radius and in some embodiments may be in the range of 0-200  $\mu\text{m}$ . The ranges may be altered by adding more polymer and increasing the nozzle diameter. For example in one sample extrusion a product was printed with a 2 mm nozzle that effectively extruded a 2 mm diameter layer. Because the diameter  $D$  of the fiber and the thickness  $T$  of the formation material layer may vary slightly over the length of the discharged composite material the dimensions provided above may be considered average dimensions of the composite material as discharged from the nozzle.

**[0081]** During the application of the continuous fiber and composite material as the part is manufactured, the continuous fiber and the formation material may be deformed and may take on more of an ellipsoidal shape in cross-section, such as shown in FIG. **9**, in the finished part. The deforma-

tion of the composite material is due to the fiber and formation material being heated to a pliable state, the pressure used to apply the fiber during the manufacturing process and the effects of gravity. As can be seen from FIG. **9**, the more the continuous fiber and formation material are compressed, the more contact surface that is created between adjacent layers of the fibers. The temperature and the pressure with which the continuous fiber is applied to the part can be controlled to thereby control the contacting surface area of each layer of fiber in the part, with areas having fibers with increase contact surface having better adherence to adjacent layers.

**[0082]** FIGS. **8** and **9** shows a partial cross-section of an exemplary part magnified to show the details of the internal structure of the part. It is to be understood that the part as shown in FIG. **9** is magnified on the order 100 times ( $\times 100$ ) so as to visibly show the structure in cross-section. Moreover, FIGS. **8** and **9** are simplified drawings of the composite material and the part as they would actually appear in magnified cross-section where microscopic surface irregularities have been omitted from the drawing. In actual magnified cross-section the surfaces of the constituent components would show surface irregularities, rough edges, imperfections and the like.

**[0083]** FIG. **9** shows a cross-section of a printed part **300** where the composite material **306** comprises a continuous fiber **302** encased within the formation material **304**. In viewing FIG. **9**, it must be understood that this is a particular cross-section of a particular section of a part. In general, regarding dimensions, these vary in accordance to the type of geometry being printed, layer heights and formation layer to filament ratio, etc. For example, the cross-section in FIG. **9** is taken from a cross-section of a curved surface of the part, as opposed to a straight section of the part. Due to this curvature, there is a difference in the amount of formation material on the left side of the cross-section compared to the right side. This is due to the curve from where the cross section was taken. For straight sections, it is more uniform, but it may be affected by a previous curve in the part. The thickness of formation material on the surface of the part can range from close to 0 mm to approaching 1 mm depending on the configuration of the part.

**[0084]** Further in viewing FIG. **9**, while the continuous fiber **302** is shown as a series of sections **302a-302e** it is to be understood that the sections form part of a single continuous fiber **302** where the plurality of sections result from the continuous fiber being cut along the section line of the drawing. The fiber is continuous in that the fiber is continuously deposited with the formation material during the 3D printing process and extends through and along each layer of the reinforced part. As a result the continuous fiber creates a continuous or substantially continuous reinforcement strand that extends in a substantially uninterrupted manner through the reinforced part. The fiber **302** may comprise a roving of fibers or a single fiber as previously described. The continuous fiber **302** is bonded to the formation material **304** by any suitable bond as previously described and may include a thermal bond, a chemical bond, a friction bond, an electrostatic bond etc. or combinations of such bonds. In some embodiments, both the continuous fiber and the formation material may be sufficiently heated to promote admixing of the formation material and the continuous fiber to form the composite material. The continuous fiber **302** is at least partially encased, and in some embodiments is

completely encased, by the formation material **304** to create the composite material **306** that forms part **300**.

**[0085]** As the continuous layers of composite material are layered against one another, on top of one another as viewed in FIG. 9, the composite material is deformed and the formation material of one layer adheres to the formation material of the adjacent layer. The composite material is cured or solidified to create a single solid structure having the desired shape.

**[0086]** In one embodiment the continuous fiber, in the finished part, has a width  $W$  of between approximately 1800  $\mu\text{m}$  (micron) and 3200  $\mu\text{m}$  where the width  $W$  is the dimension of the fiber in transverse cross-section. The distance between the bottom edge of one fiber and the bottom edge of the adjacent fiber or the height  $H$  of one layer (including the layer of formation material that is disposed between the adjacent fiber portions) is between approximately 800  $\mu\text{m}$  and 1300  $\mu\text{m}$ . The height  $H$  of a layer is composed of the thickness of the fiber ( $A$ ) and the thickness of the formation layer ( $B$ ) between the fiber layers. In one embodiment the thickness of the fiber ( $A$ ) may be equal to or less than 800  $\mu\text{m}$  and the thickness of the formation layer ( $B$ ) between the fiber layers may be between 0  $\mu\text{m}$  and 500  $\mu\text{m}$ . These dimensions can also be readily adjusted. Under the right temperature parameters and flow rates, the extruder layer would be squeezed to the sides allowing for thin and wide layers. The volumetric flow rate may be altered to obtain better layer adhesion or improve the formation of complex curves

**[0087]** The thickness of the formation material **304** over the fiber **302** on the exposed surfaces of the part vary based on the configuration of the part or portion of the part. For example, for a straight section of a part the thickness of the formation material **304** over the fiber **302** on the exposed surfaces of the part on the opposite sides of the part is approximately uniform. For a curved part the formation material **304** over the fiber **302** on the exposed surfaces of the part on the concave surface may be thicker than the formation material **304** over the fiber **302** on the exposed surfaces of the part on the convex surface. The thickness of the formation material **304** over the fiber **302** on the exposed surfaces of the part is also affected by the geometry of the adjacent curve. The thickness of the formation material on the exposed surfaces of the part may vary from near 0 to 0  $\mu\text{m}$  to approaching 1  $\mu\text{m}$ .

**[0088]** In one embodiment, the fiber volume may be approximately 23% of the total volume of the part. The void volume may be approximately 18% of the total volume of the part. The formation material may be approximately 59% of the total volume of the part. It is desirable to maintain a constant fiber volume throughout the part and to minimize the void volume. The fiber volume ratio and the void volume ratio do not signify the dimension, but it does provide critical information for the quality of the print. In general, it is desired to maintain a fairly constant fiber volume ratio and reduce the void volume ratio to a minimum. The ratio of formation material to fiber may be varied to change the appearance and structural characteristics of the part.

**[0089]** Some of the description herein is also provided in the three below patent applications, which are expressly incorporated herein by reference: 1) U.S. Provisional Application No. 62/209,573, filed Aug. 25, 2015, entitled "Integrated Robotic 3D Printing System for Printing of Fiber Reinforced Parts"; 2) U.S. patent application Ser. No.

15/246,781, filed Aug. 25, 2016, entitled "Integrated Robotic 3D Printing System for Printing of Fiber Reinforced Parts"; and 3) U.S. Provisional Patent Application No. 62/340,755, filed May 24, 2016, entitled "Composite Continuous Filament for Additive Manufacturing".

**[0090]** These and other modifications and variations to the present invention may be practiced by those of ordinary skill in the art, without departing from the spirit and scope of the present invention, which is more particularly set forth in the appended claims. In addition, it should be understood the aspects of the various embodiments may be interchanged both in whole or in part. Furthermore, those of ordinary skill in the art will appreciate that the foregoing description is by way of example only, and is not intended to limit the invention so further described in the appended claims.

1. A part comprising:

a continuous fiber substantially encased in a formation material, the fiber and formation material being arranged in a plurality of alternating layers such that the formation material of a first one of the alternating layers adheres to the formation material of a second one of the alternating layers over the length of the continuous fiber.

2. The part of claim 1 wherein the part comprises a thin-walled hollow member.

3. The part of claim 1 wherein the part comprises a duct.

4. The part of claim 1 wherein the continuous fiber extends uninterrupted for the length of the reinforced part.

5. The part of claim 1 wherein the continuous fiber has a width of between approximately 1800  $\mu\text{m}$  and 3200  $\mu\text{m}$ .

6. The part of claim 1 wherein a distance between a first edge of one layer and the first edge of the adjacent layer is less than or equal to approximately 800  $\mu\text{m}$ .

7. The part of claim 1 wherein the part has an exposed surface, the thickness of the formation material on the exposed surface is between approximately 0  $\mu\text{m}$  to approximately 1  $\mu\text{m}$ .

8. The part of claim 1 wherein the fiber volume is approximately 23% of the total volume of the part.

9. The part of claim 1 wherein the formation material is approximately 58% of the total volume of the part.

10. A duct comprising:

a thin reinforced wall having a first end and a second end and defining a hollow interior, the reinforced wall comprising a continuous fiber extending from the first end to the second end substantially encased in a formation material, the fiber and formation material being arranged in a plurality of alternating layers such that the formation material of a first one of the alternating layers adheres to the formation material of a second one of the alternating layers over the length of the continuous fiber.

11. The duct of claim 10 further comprising a non-reinforced portion.

12. A part comprising a continuous fiber prepared by an additive manufacturing process comprising the steps of:

depositing a composite material on a print bed using a print head, the composite material comprising a continuous fiber and a formation material in intimate contact with the continuous fiber;

moving the print head and/or the print bed during the depositing of the composite material;

consolidating the composite material.

13. The part of claim 12 wherein the part comprises a thin-walled hollow member.

14. The part of claim 12 wherein the part comprises a duct.

15. The part of claim 12 wherein the formation material of one layer adheres to the formation material of the adjacent layer.

16. The part of claim 12 wherein the continuous fiber has a width of between approximately 1800  $\mu\text{m}$  and 3200  $\mu\text{m}$ .

17. The part of claim 12 wherein a distance between the bottom edge of one layer and the bottom edge of the adjacent layer is less than or equal to approximately 800  $\mu\text{m}$ .

18. The part of claim 12 wherein the part has an exposed surface, the thickness of the formation material on the exposed surface is between approximately 0  $\mu\text{m}$  to approximately 1  $\mu\text{m}$ .

19. The part of claim 12 wherein the fiber volume ratio is approximately 23% of the total volume of the part.

20. The part of claim 12 wherein the formation material is approximately 59% of the total volume of the part.

\* \* \* \* \*